

AS Spilka Industri

Date: 11.02.2026



# Spilka Classic

## Product Data Sheet

Spilka Classic™ is used for horizontally top hung, fully reversible windows – also called top swing windows. The window is opened by means of a handle at its lower edge and can be shut in a narrow ventilation position via an espagnolette locking system. Classic™ has an opening restrictor as standard and opening towards this allows for an opening of about 80mm at the bottom of the window. For cleaning, the window may be swung 180° and the opening restrictor will then engage, holding the window firmly in position. The window does not swing into the room, and therefore curtains and potted plants on the windowsill are not disturbed.

The Spilka Classic system solution is described in reference item 1.1 in “table A”.

## Product Information:

Spilka Classic is available in eight sizes, designated S1 – S8. The smallest window height is 388mm and the tallest window height is 1788mm and maximum width is 2488 mm. The largest sash weight for the standard Spilka Classic is 80kg.

We also offer Spilka Classic HD, a hinge variant with a reinforced frame plate for sashes weighing up to 80kg. Classic HD is available in hinge sizes S6 and S7 and we emphasize that the window producer must consider whether the profile is strong enough for the increased weight.

The “table A”, item 1.2 describes weight capacity for the S1 – S8 hinge sizes in addition to a link to the Classic sash weight calculator. Also indicated here are the recommended window sizes (heights and widths) and the appropriate hinge sizes.

## Application:

Windows with the Spilka Classic system solution are opened by means of a handle on the lower part of the sash which operates an espagnolette system. Spilka Classic™ hinges incorporate an opening restrictor as a standard; this limits the initial opening of the window to about 80mm. A ventilation device is offered as an added feature, alongside an opening restrictor as well as a lock for the opening restrictor. Please be aware that the lock for the opening restrictor is designed for the sizes S4–S8 (window heights exceeding 755mm).

Maintenance and correct use are important to maintain functionality and useful life for both hinges and windows. An overview of the maintenance is shown in chapter “Maintenance” on page 7.

## Profile description and interface information:

The “table A”, item 1.3 give references to the profile design and interface instructions for Spilka Classic.

## Surface treatment:

Classic hinges in steel have been surface treated with electrolytic zinc and given a passivation coating of Chrome (Cr) in trivalent form and thereafter a sealer. Chromium in trivalent form is more environmentally friendly than in a hexavalent form. The passivation coating bonds with the top layer of the zinc and along with the sealer the hinge becomes more corrosion resistant. The surface treatment leaves the hinges with a light grey color. An overview of the corrosion protection is shown in chapter “Corrosion resistance” on page 5.

## Maintenance (FDV)

Hinges are used in windows in the facades of the buildings and to maintain functionality and desired service life, correct use and maintenance are required. We have prepared an overview with recommendations for what is needed in terms of continuous maintenance, but we emphasize that local conditions such as weather, proximity to the sea/water etc. are decisive for how often such maintenance must be repeated. An overview of the FDV is shown in chapter "Repair and Maintenance" on page 6–8.

## Interface documentation:

The "table A" give references to relevant technical documentation for the Spilka Classic hinge.

Item	Description	Document no:
1.1	Classic hinge system solution	4-32-15 Classic hinge system solution
1.2	Classic size and capacity overview	Classic sash weight calculator
		4-24-76 Classic size and capacity overview
1.3	Profile design and interface instruction	220714 Construction manual Spilka Classic
		220714 Monteringsanvisning Spilka Classic
1,4	Products and Accessories for Classic Hinges	PDS-Spilka Product and Accessories Classic-v01-2022

Table A

## Products and Accessories:

Spilka can offer a variety of products and accessories together with the hinge system, item 1.4 in "table A" give references to the available products and accessories for door and windows.

# Operation and Functionality:

## OPERATION

Certain hardware components require manual operation:

### Opening restrictor

Fitted to the left-hand hinge (viewed from outside) this device limits initial opening to about 80 mm and automatically re-engages when the sash is reversed for cleaning. It is operated by slightly closing the sash after it has opened out against the restrictor and then lifting the restrictor catch up to release the sash for further opening.

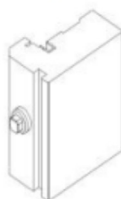
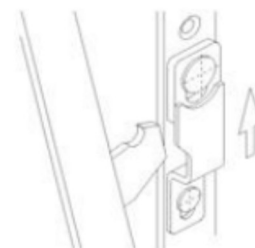

### Catch lifter

This may be fitted as an option to allow the opening restrictor to be operated by pushing an internal button. As the component is installed behind the u-channel it is suitable only for factory fitting and is only available for windows more than 610 mm high.

### Lock for opening restrictor

An opening restrictor lock is available for hinge sizes S4, S5, S6, S7 and S8 i.e., windows more than 755 mm high. The restrictor lock will block the release of the opening restrictor, reducing the risk of inadvertent opening from inside – or outside – but the window should not then be regarded as an escape route! To install, the opening restrictor is held down while the 'lock' is pushed up between the hinge frame plate and catch (see illustration). A flat head screwdriver may be used to do this. To remove the lock, use a screwdriver to push it downwards whilst holding the opening restrictor in the closed position. The lock may be fitted by the window manufacturer or may be easily retrofitted to existing windows.

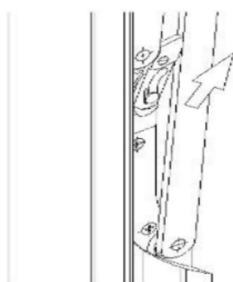
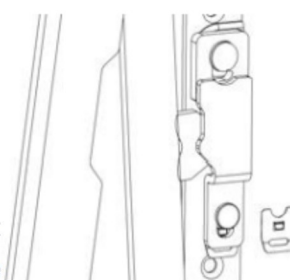

### 'Blowback restrictor'

Fitted to the right-hand hinge (as seen from the outside) the blowback restrictor is manually engaged by pushing it upwards when the sash is opened against the opening restrictor, it then holds the sash open at approximately 80 mm preventing it from being blown closed. It must be manually disengaged before the sash is closed. The restrictor may be factory fitted by the window producer or easily 'retro fitted' by the householder. The restrictor comes in three sizes, which can be used on S3 – S8.

### Ventilation device

In certain situations, it may not be possible for the sash to be reversed into the washing position and for the opening restrictor to fully re-engage. We have developed a component, which is screwed to the right-hand hinge (as viewed from outside) and is manually hooked over the lower hinge arm when a wider opening is required; it is manually disengaged before the sash is closed. The device may be factory fitted by the window producer or on-site by the builder or householder.

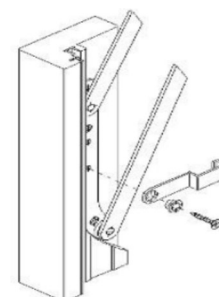

# Spilka Hardware – Corrosion Resistance:

Spilka is a supplier of hinges for windows. The Norwegian window manufacturers have their window certificated in a control organization called NDVK (Norwegian Door and Window Control).

These manufacturers are only allowed to use “approved” hinges. This means that the hinges must satisfy standard NS-EN 1670 grade 3.

Standard NS-EN 1670: Corrosion resistance specifies the requirements for the corrosion resistance of hardware for windows:

## 4 Classification

Grade (class) 3: High resistance

The requirement of corrosion for NDVK is grade (class) 3.

## 5.4 Electrodeposited zinc on iron or steel

If coated with electroplated zinc on iron or steel, the requirements of the appropriate classification code of ISO 2081 plus a chromate conversion coating meeting the requirements of the class of ISO 4520 specified to match that classification, shall be as follows:

- Grade (class) 3:

ISO 2081 classification code Fe/Zn 12 + ISO 4520 class 2C or 2D.

Spilka Classic hinges are made of steel with the following corrosion protection: Zinc electroplated, thickness min. 15 µm.

Passivated with bright chromate Cr (III).

Sealer.

This treatment satisfies EN 1670.

Spilka Industri is certificated according to our Quality System that complies with NS-EN ISO 9001- 2015

# Spilka Classic Hardware – Repair and Maintenance:

These are guidelines for the repair and maintenance of Spilka Classic window hardware, including hinges, center sash assemblies and head slides. Instructions are provided for the replacement or repair of damaged items or those needing replacement through wear and tear.

## Material and Environment

Hinges are produced from standard grade steel of which 50% is from recycled materials and the hinges may themselves be continuously recycled. They are surface treated with zinc, chromate and then given a coat of clear lacquer. None of our hardware requires special handling or considerations due to their treatment or production.

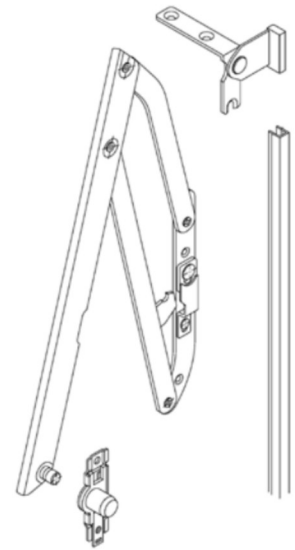

## Quality Assurance and Guarantees

Spilka hardware is produced under a quality control system in accordance with requirements for the NDVK (Norwegian Door- and window control) and AS Spilka Industri has a license from their control body. Below are details of relevant requirements and qualities.

### Strength

Opening the sash until the hinges are fully extended tests the window/hardware. A vertical load of 50kg is then applied to the top of the sash while the bottom is held fixed. This gives a total loading on the hinges of up to 3 times the maximum sash weight. Our hardware is designed to accept these loadings to provide a considerable safety margin in operation and longevity in service.

NOTE! Damage may be caused to the opening restrictor if exceptional force is applied before it is lifted to allow the sash to reverse. Damage caused in this way would not be covered by our guarantee.

### Wear and tear

Windows are tested by opening and closing over 20 000 cycles with their maximum sash weight, this should correspond with the daily opening of a window over its lifetime.

NOTE! Damage may be caused if relevant maintenance is not carried out, or by opening the safety restrictor with excessive force. Damage caused in this way will not be covered by our guarantee.

### Corrosion

The requirement for surface treatment is a minimum of 12 µm thickness of zinc and passivated with chrome. According to the NDVK this gives a performance level as follows: "Fittings in Class 3 are suitable for use in wet or polluted environments and also salt, acid or alkaline conditions. This includes special humid conditions inside buildings and most external conditions".

NOTE! Hardware life expectancy before corrosion will depend on climate conditions and material

# Maintenance:

Hardware is used in window construction and thereby as a part of a building's facade. It is important that all items receive relevant initial treatment and that correct maintenance is carried out to ensure continuing operation. Maintenance requirements may vary dependent on local conditions and should be increased as appropriate.

## Lubrication of opening restrictor

A few drops of light oil should be applied behind the restrictor, and it should be slid up and down to ensure the oil spreads. Apply a little oil to the 'hook' which engages the restrictor, to ensure smooth operation.

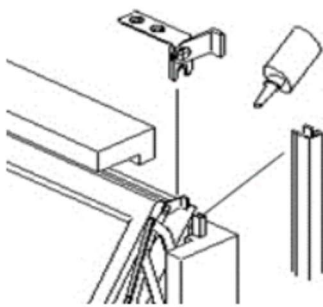
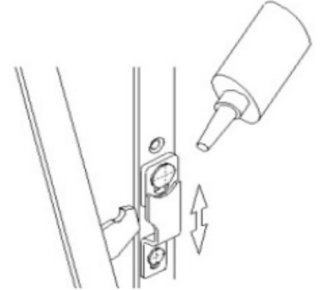

## Lubrication of head slides and u-channel

Completely open the sash and place a few drops of oil on the white plastic part of each head slide as far as possible within the u-channel. Also lightly lubricate the pivot point on the head slide before turning the sash several times to ensure smooth operation. It is important that paint or stain is not introduced into the uchannel during decoration.

## Decoration of hinges

Hinges may be painted for esthetic considerations or simply to provide further corrosion resistance. The visible arms of the hinges may be provided powder coated or wet-painted as a factory option and this provides the most durable finish. Before site painting hinges should be thoroughly cleaned and degreased with white spirit or similar. Particular attention should be paid to rivets and pivot points. It is important that paint or stain is not introduced into the 'moving parts' of the window hardware. Lubrication of moving parts should be done more often in corrosive environments and situations.

# Repairs and Replacements:

Damaged components should usually be replaced. Fitting instructions may be found on our website and these details may be used to order replacement items by their descriptions and part numbers.

## Head slides

Open the window wide enough to loosen or remove the screw(s) from the groove in the side of the sash. Then remove the screws holding the head slide onto the top of the sash. Pull or press the head slide off the sash and out of the u-channel before fitting the new component and replacing all screws.

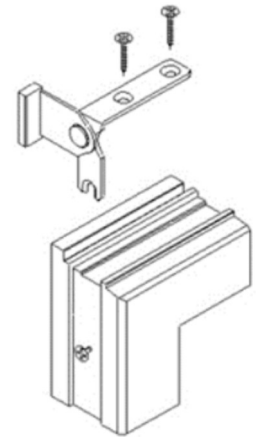

## Hinges

Personnel with relevant skills should generally carry this out, as it may be difficult and potentially dangerous dependent on the situation and health and safety requirements.

The sash is reversed almost to the washing position and a block is wedged between the lower sash (now reversed) and the windowsill section. The (reversed) lower sash is then secured against the frame head. The sash weight will now be off the hinges.

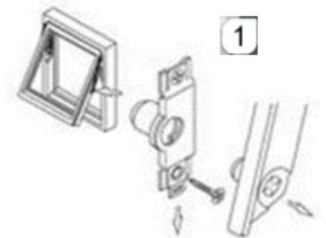

The hinge is fitted to the sash through a center sash assembly. Spilka offers two different center sash assemblies – 1) with a locking slide, 2) with a secured string, also known as the Rondo.

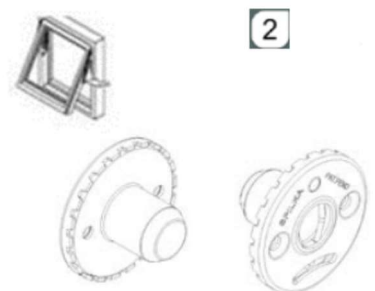

When using the center sash assembly alternative 1), its locking slide is released by removing its retaining screw. Once released, the hinge pivot point is pulled free.

For windows with center sash assembly alternative 2), the hinge pivot point is simply released by using a thin thong to release its spring.

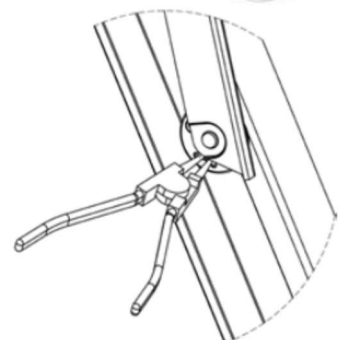

The hinge is fixed to the frame by a screw, this can now be removed, and the replacement hinge may then be fitted. Only one hinge should be replaced at a time 'in-situ'.

NOTE! It is vital to replace the relevant pins and screws before the sash is reversed again to ensure the sash does not fall out

## Profile Materials:

### Material types:

Windows with Spilka Side-hung hinges can be produced with the same timber profiles used for our Classic, Opus and Swing hardware options.

Our R&D Department will give a quick clarification as to whether our hinge variants can be used directly in your current window profile.

Side hung windows can also be produced in PVCu, fibre glass and aluminium – dependent on the relevant profile construction.

Spilka Side-hung hinges are stocked in white (RAL 9010), grey (RAL 7035) and black (RAL 9011). They have flat end caps in a durable plastic material. We also provide decorative knobs in the same quality plastic. Use of knobs require that the flat end caps are removed manually.

### Wood:

Windows made of wood continue to be the predominant choice in Scandinavia. Softwood (pine) is the most common wood where a large part should be heart wood for a more solid profile. Laminated profiles ensure a more stable construction, and it is common to use spruce for the outer lamina (layers) – which is more durable as it has a closed cell structure.

An increasing number of wooden windows are now delivered with aluminium cladding, and Spilka can assist with the design and delivery of such aluminium profiles.

### PVC (vinyl):

Window frame and connecting profiles of extruded PVCu, also known as vinyl or plastic, can be used in the production of windows with Spilka's system solutions.

### Aluminium:

Aluminium is a well-known material which has many applications and is a light metal with great strength in relation to its weight. Aluminium is a good choice due to its durability, minimal complications linked to corrosion and its flexible profile design possibilities.